



US009357064B1

(12) **United States Patent**
Walton

(10) **Patent No.:** **US 9,357,064 B1**
(45) **Date of Patent:** **May 31, 2016**

- (54) **APPARATUSES AND METHODS FOR ROUTING DIGITAL VOICE DATA IN A COMMUNICATION SYSTEM FOR HEARING-IMPAIRED USERS**
- (71) Applicant: **CaptionCall, LLC**, Salt Lake City, UT (US)
- (72) Inventor: **Sean Walton**, Orem, UT (US)
- (73) Assignee: **CAPTIONCALL, LLC**, Salt Lake City, UT (US)
- (*) Notice: Subject to any disclaimer, the term of this patent is extended or adjusted under 35 U.S.C. 154(b) by 0 days.

6,075,842 A	6/2000	Engelke et al.	
6,112,103 A *	8/2000	Puthuff	H04M 1/247 455/550.1
6,233,314 B1	5/2001	Engelke	
6,307,921 B1	10/2001	Engelke et al.	
6,493,426 B2	12/2002	Engelke et al.	
6,504,910 B1	1/2003	Engelke et al.	
6,510,206 B2	1/2003	Engelke et al.	
6,549,611 B2	4/2003	Engelke et al.	
6,567,503 B2	5/2003	Engelke et al.	
6,594,346 B2	7/2003	Engelke	
6,603,835 B2	8/2003	Engelke et al.	
6,748,053 B2	6/2004	Engelke et al.	
6,882,707 B2	4/2005	Engelke et al.	
6,885,731 B2	4/2005	Engelke et al.	
6,934,366 B2	8/2005	Engelke et al.	
7,003,082 B2	2/2006	Engelke et al.	
7,006,604 B2	2/2006	Engelke et al.	
7,164,753 B2	1/2007	Engelke et al.	

(Continued)

- (21) Appl. No.: **15/005,828**
- (22) Filed: **Jan. 25, 2016**

Primary Examiner — Maria El-Zoobi
(74) *Attorney, Agent, or Firm* — TraskBritt

Related U.S. Application Data

- (63) Continuation of application No. 14/709,303, filed on May 11, 2015, now Pat. No. 9,247,052.
- (60) Provisional application No. 62/079,872, filed on Nov. 14, 2014.

- (51) **Int. Cl.**
H04M 11/04 (2006.01)
H04M 3/42 (2006.01)
- (52) **U.S. Cl.**
CPC *H04M 3/42391* (2013.01)
- (58) **Field of Classification Search**
None
See application file for complete search history.

(57) **ABSTRACT**

A communication system facilitating communication for assisting hearing-impaired users includes an analog telephone adaptor (ATA) device and a communication device. The communication device is configured to route digital voice data between the ATA device and a second communication device during a conversation involving the communication device and a second communication device through a wireless port of communication device, and communicate through the wireless port with a relay service configured to provide interpretive assistance for a hearing-impaired user of the communication device. A method includes routing digital voice data received wirelessly by a communication device to an ATA device, routing digital voice data received from the ATA device from the communication device wirelessly to a second communication device, and communicating wirelessly with a relay service configured to provide captioning services of the content of a portion of the voice data received by the communication device from the second communication device.

(56) **References Cited**

U.S. PATENT DOCUMENTS

5,909,482 A	6/1999	Engelke
5,974,116 A	10/1999	Engelke et al.
5,978,654 A	11/1999	Colwell et al.
6,075,841 A	6/2000	Engelke et al.

20 Claims, 4 Drawing Sheets

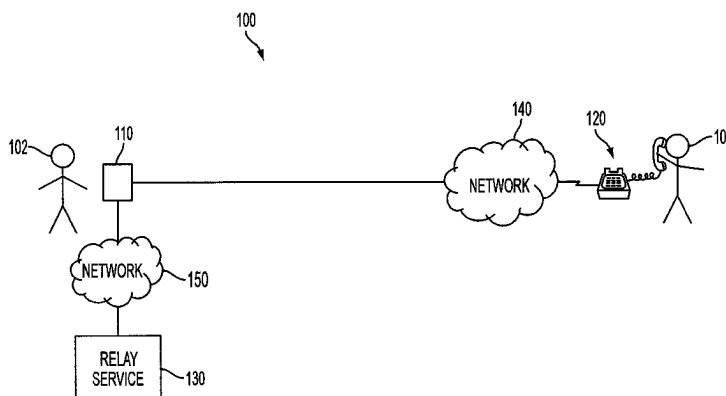

(56)

References Cited

U.S. PATENT DOCUMENTS

7,319,740	B2	1/2008	Engelke et al.	8,917,821	B2	12/2014	Engelke et al.	
7,555,104	B2	6/2009	Engelke	8,917,822	B2	12/2014	Engelke et al.	
7,660,398	B2	2/2010	Engelke et al.	9,247,052	B1	1/2016	Walton	
7,881,441	B2	2/2011	Engelke et al.	2004/0010323	A1*	1/2004	Martin	H04L 41/046
8,213,578	B2	7/2012	Engleke et al.					700/3
8,379,801	B2	2/2013	Romriell et al.	2008/0101552	A1*	5/2008	Khan	H04L 12/66
8,416,925	B2*	4/2013	Engelke					379/45
		 G10L 15/265	2008/0187108	A1	8/2008	Engelke et al.	
			379/52	2011/0170672	A1	7/2011	Engelke et al.	
8,908,838	B2	12/2014	Engelke et al.	2012/0250837	A1	10/2012	Engleke et al.	

* cited by examiner

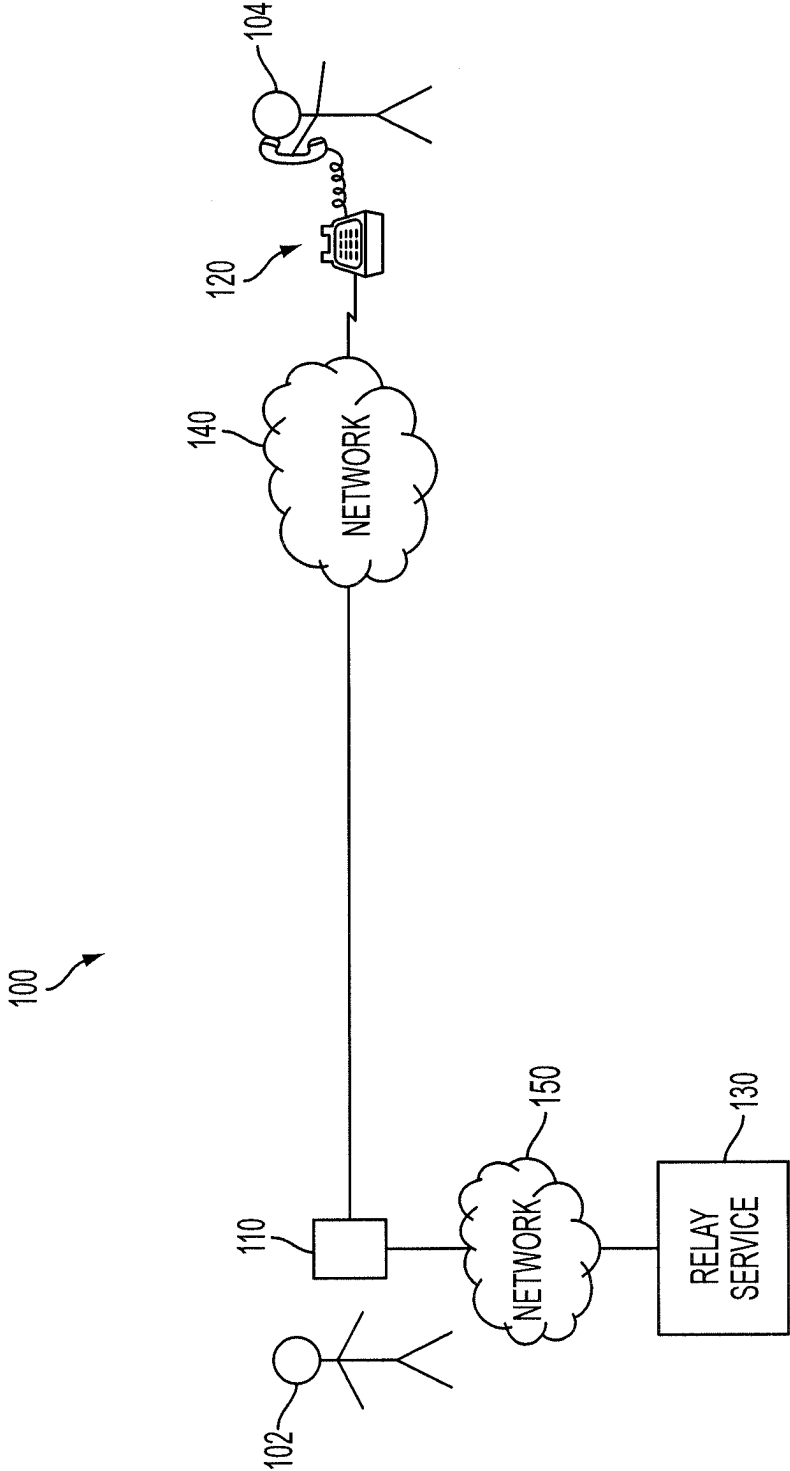

FIG. 1

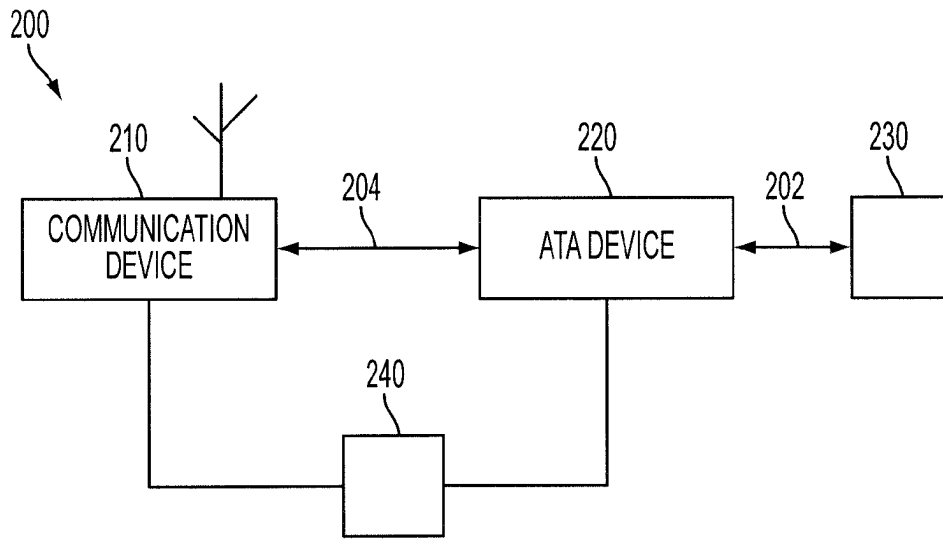

FIG. 2
(PRIOR ART)

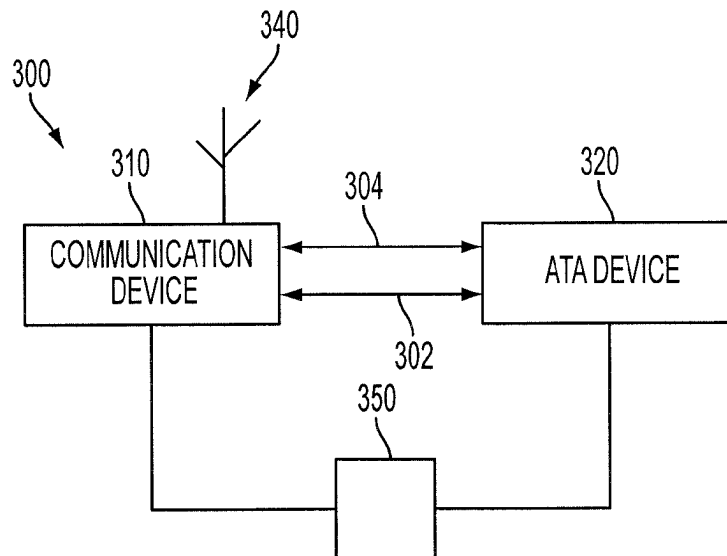

FIG. 3

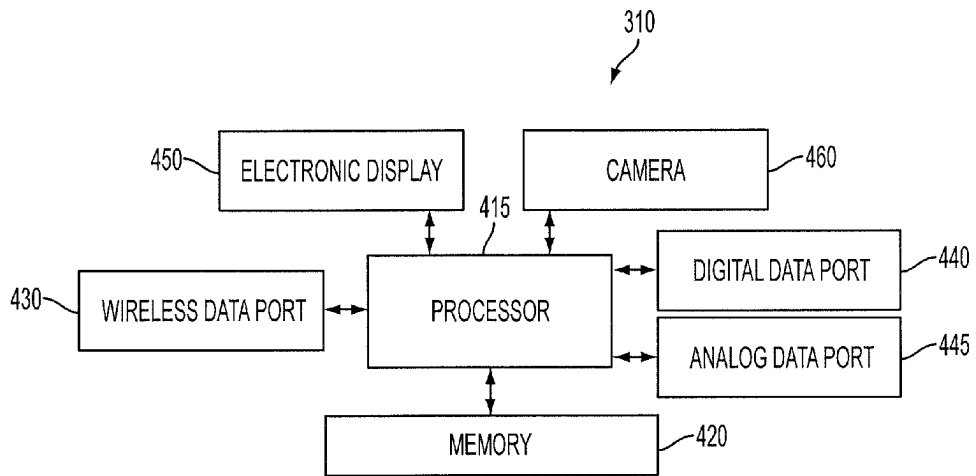

FIG. 4

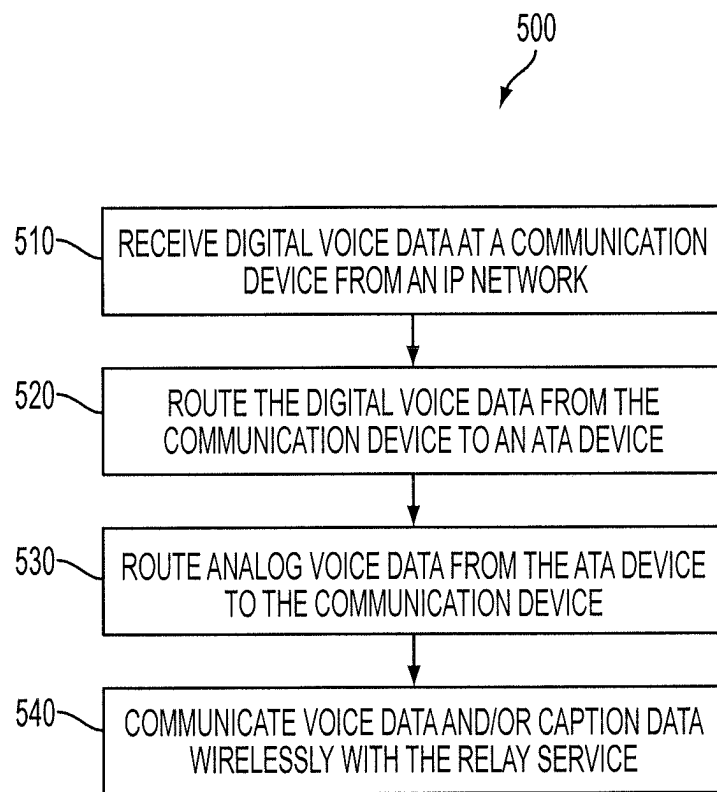

FIG. 5

**APPARATUSES AND METHODS FOR
ROUTING DIGITAL VOICE DATA IN A
COMMUNICATION SYSTEM FOR
HEARING-IMPAIRED USERS**

CROSS-REFERENCE TO RELATED
APPLICATION

This application is a continuation of U.S. patent application Ser. No. 14/709,303, filed May 11, 2015, U.S. Pat. No. 9,247,052 (Jan. 26, 2016), which claims the benefit of U.S. Provisional Patent Application Ser. No. 62/079,872, filed Nov. 14, 2014, the disclosure of each of which is hereby incorporated herein in its entirety by this reference.

TECHNICAL FIELD

Embodiments of the disclosure relate to the routing voice data in a communication network. More particularly, the disclosure relates to routing of digital voice data between a communication device and an analog telephone adaptor in a system that facilitates communication for hearing-impaired users employing a relay service for assistance.

BACKGROUND

Communication systems provide communication between two or more users during a communication session. Such communication system may include devices that assist hearing-impaired users to have a substantially functionally-equivalent experience as a hearing user using conventional communication devices. Many such communication devices include text captioned phones, video phones, and the like, which may communicate with a relay service providing interpretive services (e.g., captioning, sign language interpreting, etc.) for the hearing-impaired user. Many of these communication devices being are only configured for performing the communication in an analog domain (e.g., the voice data may only be analog) even though other digital data (e.g., captions) may be received. Some users wanting to connect such devices to internet-based (e.g., VoIP) networks may use analog telephone adaptors to perform the conversion of the voice signals between analog and digital domains. The use of such analog telephone adaptors may limit the locations that the user may place the communication devices because of wiring and other costs associated therewith.

BRIEF SUMMARY

Described is a communication device for use with a hearing-impaired user. The communication device includes a wireless data port, a digital data port, an analog data port, and a processor operably coupled with the wireless data port, the digital data port, and the analog data port. The processor is configured to communicate through the wireless data port with a relay service for assisting hearing-impaired users to communicate with others, communicate through the wireless data port with a second communication device to transmit and receive digital voice data during a conversation, and route the digital voice data to an analog telephone adaptor (ATA) device through the digital data port.

In some embodiments, disclosed is a communication system facilitating communication for assisting hearing-impaired users. The communication system includes an analog telephone adaptor (ATA) device, and a communication device operably coupled with the ATA device. The communication device is configured to route digital voice data between the

ATA device and the relay service during a conversation involving the communication device and a second communication device through a wireless port of communication device, and communicate through the wireless port with a relay service configured to provide interpretive assistance for a hearing-impaired user of the communication device.

In some embodiments, disclosed is a communication system. The communication system includes a relay service configured to provide interpretive services for hearing-impaired users, a communication device operably coupled with the relay service, and an analog telephone adaptor (ATA) device operably coupled with the communication device.

The communication device is configured to provide the interpretive services from the relay service to a hearing-impaired user of the communication device. The ATA device is configured to convert digital voice data received from the communication device to analog voice data, transmit the analog voice data to the communication device, convert analog received from voice data from the communication device to digital voice data, and transmit the digital voice data to the communication device. The communication device is further configured to route the digital data between the ATA device and a second communication device.

In some embodiments, disclosed is a method of facilitating communication in a communication network including a communication device and a relay service. The method includes routing digital voice data received wirelessly by a communication device to an analog telephone adaptor (ATA) device, routing digital voice data received from the ATA device from the communication device wirelessly to a second communication device, and communicating wirelessly with a relay service configured to provide captioning services of the content of at least a portion of the voice data received by the communication device from the second communication device.

BRIEF DESCRIPTION OF THE SEVERAL
VIEWS OF THE DRAWINGS

FIG. 1 illustrates a communication system configured to facilitate a communication session between a hearing-impaired user and a hearing-capable user hereof.

FIG. 2 is a simplified block diagram of a portion of a communication system showing a conventional configuration of a communication device communicating with external networks.

FIG. 3 is a simplified block diagram of a portion of a communication system showing a configuration of a communication device communicating with external networks according to an embodiment of the disclosure.

FIG. 4 is a simplified block diagram of the communication device of FIG. 3.

FIG. 5 is a simplified flowchart illustrating a method of facilitating communication in a communication network including a communication device and a relay service according to an embodiment of the disclosure.

DETAILED DESCRIPTION

In the following detailed description, reference is made to the accompanying drawings that form a part hereof, and in which is shown by way of illustration, specific embodiments in which the disclosure may be practiced. These embodiments are described in sufficient detail to enable those of ordinary skill in the art to practice the disclosure. It should be understood, however, that the detailed description and the specific examples, while indicating examples of embodi-

ments of the disclosure, are given by way of illustration only and not by way of limitation. From this disclosure, various substitutions, modifications, additions, rearrangements, or combinations thereof within the scope of the disclosure may be made and will become apparent to those of ordinary skill in the art.

In accordance with common practice, the various features illustrated in the drawings may not be drawn to scale. The illustrations presented herein are not meant to be actual views of any particular apparatus (e.g., device, system, etc.) or method, but are merely idealized representations that are employed to describe various embodiments of the disclosure. Accordingly, the dimensions of the various features may be arbitrarily expanded or reduced for clarity. In addition, some of the drawings may be simplified for clarity. Thus, the drawings may not depict all of the components of a given apparatus or all operations of a particular method.

Information and signals described herein may be represented using any of a variety of different technologies and techniques. For example, data, instructions, commands, information, signals, bits, symbols, and chips that may be referenced throughout the description may be represented by voltages, currents, electromagnetic waves, magnetic fields or particles, optical fields or particles, or any combination thereof. Some drawings may illustrate signals as a single signal for clarity of presentation and description. It should be understood by a person of ordinary skill in the art that the signal may represent a bus of signals, wherein the bus may have a variety of bit widths and the disclosure may be implemented on any number of data signals including a single data signal.

The various illustrative logical blocks, modules, and circuits described in connection with the embodiments disclosed herein may be implemented or performed with a general-purpose processor, a special-purpose processor, a Digital Signal Processor (DSP), an Application Specific Integrated Circuit (ASIC), a Field Programmable Gate Array (FPGA) or other programmable logic device, discrete gate or transistor logic, discrete hardware components, or any combination thereof designed to perform the functions described herein.

A processor herein may be any processor, controller, microcontroller, or state machine suitable for carrying out processes of the disclosure. A processor may also be implemented as a combination of computing devices, such as a combination of a DSP and a microprocessor, a plurality of microprocessors, one or more microprocessors in conjunction with a DSP core, or any other such configuration. When configured according to embodiments of the disclosure, a special-purpose computer improves the function of a general-purpose computer because, absent the disclosure, the general-purpose computer would not be able to carry out the processes of the disclosure. The disclosure also provides meaningful limitations in one or more particular technical environments that go beyond an abstract idea. For example, embodiments of the disclosure provide improvements in the technical field of telecommunications, communication devices connected to a relay service, and other related technical fields. In particular, embodiments of the disclosure may improve the flow of data and provide additional options for connectivity such that the communication device itself and the communication system may be improved upon over conventional embodiments.

In addition, it is noted that the embodiments may be described in terms of a process that is depicted as a flowchart, a flow diagram, a structure diagram, or a block diagram. Although a flowchart may describe operational acts as a sequential process, many of these acts can be performed in another sequence, in parallel, or substantially concurrently. In

addition, the order of the acts may be re-arranged. A process may correspond to a method, a function, a procedure, a subroutine, a subprogram, interfacing with an operating system, etc. Furthermore, the methods disclosed herein may be implemented in hardware, software, or both. If implemented in software, the functions may be stored or transmitted as one or more instructions (e.g., software code) on a computer-readable medium. Computer-readable media includes both computer storage media and communication media including any medium that facilitates transfer of a computer program from one place to another.

It should be understood that any reference to an element herein using a designation such as “first,” “second,” and so forth does not limit the quantity or order of those elements, unless such limitation is explicitly stated. Rather, these designations may be used herein as a convenient method of distinguishing between two or more elements or instances of an element. Thus, a reference to first and second elements does not mean that only two elements may be employed there or that the first element must precede the second element in some manner. Also, unless stated otherwise a set of elements may comprise one or more elements.

As used herein, a hearing-impaired user may be a person with diminished hearing capabilities. Some hearing-impaired users may have some level of hearing and/or speaking ability, while others may not have any such ability. Hearing-impaired users may need to be certified in order to access the communication system.

FIG. 1 illustrates a communication system **100** configured to facilitate a communication session between a hearing-impaired user **102** and a hearing-capable user **104** according to an embodiment of the disclosure. The communication system **100** may include a first communication device **110**, a second communication device **120**, and a relay service **130**. The first communication device **110** and the second communication device **120** may be coupled together to facilitate communication therebetween via a first network **140**. The first communication device **110** and the relay service **130** may be coupled together to facilitate communication therebetween via a second network **150**. For example only, the first network **140** and the second network **150** may each be implemented according to the standards and bandwidth requirements of a communication network (e.g., Public Switch Telephone Network (PSTN), cellular network, Voice Over Internet Protocol (VOIP) networks, etc.). The use of the terms “network” or “communication network” as used herein contemplates networks that are compatible and configured to provide communications using analog and/or digital standards unless specifically stated otherwise. In some embodiments, the first network **140** and the second network **150** may be the same network (e.g., both connections may be Internet-based connections). Thus, discussion of the first network **140** and the second network **150** separately may be for convenience of discussing a particular connection between two or more devices. Of course, in some embodiments, the first network **140** and the second network **150** may be different networks. For example, the first communication device **110** and the second communication device **120** may communicate via a PSTN network connection, while the first communication device **110** and the second communication device **120** may communicate via an internet connection. Other variations and combinations of networks are also contemplated.

The first communication device **110** may include a device that is configured to assist the hearing-impaired user **102** in communicating with another individual (e.g., hearing-capable user **104** or another hearing-impaired user). In some embodiments, the first communication device **110** may

include a captioned telephone, a telephone enabled for text enhanced telephony, or any other suitable communication device configured to receive and display a text caption of at least a portion of the conversation. Thus, the hearing-impaired user **102** may be able to read a caption of the words spoken by the hearing-capable user **104** to supplement the audio generated by the first communication device **110** from the voice signal received by the first communication device **110**. As a result, the hearing-impaired user **102** may have an improved experience in understanding the conversation. Such an embodiment may be useful for people whose hearing has been damaged or decreased over time (e.g., the elderly); such that they can still speak but have diminished hearing that makes it difficult to communicate. In some embodiments, the first communication device **110** may include a communication device (e.g., video telephone) configured to receive and display video on an electronic display on the first communication device **110**. In addition, the first communication device **110** may include a camera configured to capture and transmit a video signal to the relay service **130** and/or the second communication device **120**. As a result, the hearing-impaired user **102** may be able to use visual communication (e.g., sign language) to communicate with others. Such an embodiment may be useful for people whose hearing has been damaged or decreased over time, but who may not be able to verbally communicate well and/or have such damaged hearing that they cannot hear.

The second communication device **120** may comprise a conventional voice telephone (e.g., landline phone, cellular phone, smart phone, VoIP phone, etc.). As such, the hearing-capable user **104** may interact in a conventional manner with the second communication device **120**. In some embodiments, the second communication device **120** may be configured similarly as the first communication device (e.g., captioned phone, video phone, etc.). As a result, the second communication device **120** may likewise be operated by a hearing-impaired user. Thus, although facilitating communication between the hearing-impaired user **102** and the hearing-capable user **104** is shown in FIG. 1, such a situation is shown only as an example. Other embodiments include both the first communication device **110** and the second communication device **120** coupled to the relay service **130** to facilitate the interpretive services for each respective hearing-impaired user.

The relay service **130** may be configured to provide interpretive services (e.g., captioning, video) to the hearing-impaired user **102**. More specifically, a human “call assistant” within relay service **130** may be employed to facilitate a communication session between a hearing-impaired user **102** and a hearing-capable user **104**. As discussed above, in some embodiments the relay service **130** may be configured to provide text captions of at least a portion of the conversation. In such an embodiment, the call assistant may listen to the voice signal received and re-voice the portion of the conversation into a microphone so that voice recognition software may generate the text transcription that is transmitted to the first communication device **110**. In some embodiments, the relay service **130** may be configured to provide sign language interpretive services. In such an embodiment, the call assistant may communicate with the hearing-impaired user **102** over a video connection (e.g., via sign language), and then the call assistant may then communicate with the hearing-capable user over a voice connection. Thus, the relay service **130** may include one or more of an internet protocol captioned telephone service (IPCTS), captioned telephone service (CTS), video relay service (VRS), or other telecommunications relay services (TRS).

FIG. 1 shows a configuration where the first communication device **110** acts as a router for the voice signal from the second communication device **120** to the relay service **130**. In such an embodiment, the voice signal of the hearing-capable user **104** may be transmitted from the second communication device **120** to the first communication device **110**. The voice signal of the hearing-capable user **104** may then be transmitted from the first communication device **110** to the relay service **130** for the text transcription to be generated in a text captioning embodiment. The text transcription may then be transmitted from the relay service **130** to the first communication device **110** to be displayed as a text caption for the hearing-impaired user to read during the conversation. The call assistant may also monitor the text transcription that is generated and transmitted to the first communication device **110** to identify any errors that may have been generated by the voice recognition software. The call assistant may correct such errors, such as described in U.S. Pat. No. 8,379,801, issued Feb. 19, 2013, entitled “Methods and Systems Related to Text Caption Error Correction,” the disclosure of which is incorporated herein in its entirety by this reference. In some embodiments the relay service **130** may be configured to receive the voice signal from the second communication device **120** and route the voice signal to the first communication device **110**. In some embodiments, another device may receive the voice signal from the second communication device **120** and split the voice signal to route to both the first communication device **110** and the relay service **130**.

In addition, although FIG. 1 shows only two communication devices **110**, **120**, the communication system **100** may include more communication devices. It is contemplated that the communication system **100** may facilitate communication between any number and combinations of hearing-impaired users and hearing-capable users. For example, in some embodiments two or more communication devices may be connected for facilitating communication between a hearing-impaired user and other hearing-impaired users and/or hearing-capable users.

Prior to use of the first communication device **110**, the first communication device **110** is installed at an installation location. The installer may be the hearing-impaired user **102** in some embodiments. In some embodiments, a trained technician may install the first communication device **110** for the hearing-impaired user **102**. This may be helpful as the trained technician may provide the hearing-impaired user **102** with installation assistance, troubleshooting, training on the use, answering additional questions, etc., which may be particularly helpful for individuals who are not technologically inclined or are unfamiliar with the unique features of the first communication device **110**.

FIG. 2 is a simplified block diagram of a portion of a communication system **200** showing a conventional configuration of a communication device **210** communicating with external networks. This illustration may represent an example of a configuration within installation location for the communication device **210** (e.g., the hearing-impaired user’s residence). The communication device **210** may be operably coupled with an analog telephone adaptor (ATA) device **220** for communication therebetween. The ATA device **220** may be operably coupled with a connector **230** (e.g., Ethernet patch connector) for communication therebetween. The communication device **210** and the ATA device **220** may also be coupled with a power source **240** (e.g., via a wall AC power outlet).

The ATA device **220** may communicate (e.g., transmit and receive) digital voice data **202** (e.g., VoIP data) through the connector **230** (e.g., Ethernet patch connector). The digital

voice data **202** may include the voice signals passing to and from the second communication device **120** (FIG. 1) during a conversation. The ATA device **220** may be configured to convert the incoming digital voice data **202** into analog voice data **204** that is transmitted to the communication device **210**. Similarly, the ATA device **220** may be configured to convert the outgoing analog voice data **204** into digital voice data **202** that is transmitted to the second communication device **120**. As a result, the communication device **210** that itself is not configured to communicate over a digital voice network even if the communication device **210** itself does not support digital voice data **202**. Thus, the ATA device **220** may assist in this process by providing the conversion of the voice data between the analog and digital domains.

In some embodiments, the communication device **210** may include a wireless port that is configured to communicate data wirelessly with the relay service **130** (FIG. 1). The data communicated with the relay service **130** may include electronic packet switching service (EPSS) data and caption call service (CCS) data. For example, the data may include voice signal data (e.g., of the far end) that the communication device **210** may transmit to the relay service **130**. The data may also include the text caption data that the relay service **130** transmits back to the communication device **210** for display.

Because the connection of communication device **210** and the ATA device **220**, and the connection of the ATA device **220** and the connector **230** are conventionally wired connections (e.g., Ethernet cables), there may be limitations as to the places that the ATA device **220** and the communication device **210** may be located as they will need to be located relatively close to the connector **230** for the wired connection therebetween. Thus, hearing-impaired users may only be able to locate the communication device **210** at locations that where their physical network cables can reach the connector **230**.

FIG. 3 is a simplified block diagram of a portion of a communication system **300** showing a configuration of a communication device **310** communicating with external networks according to an embodiment of the disclosure. This illustration may represent an example of a configuration within installation location for the communication device **310** (e.g., the hearing-impaired user's residence). The communication device **310** may be operably coupled with an ATA device **220** for communication therebetween. The communication device **210** and the ATA device **220** may also be coupled with a power source **350** (e.g., via a wall AC power outlet).

The communication device **310** may include a wireless port **340** that is configured to communicate data wirelessly with both the relay service **130** (FIG. 1) and the second communication device **120** (FIG. 1). The data communicated with the relay service **130** may still be facilitated by the communication device **310** and its wireless port **340**. Such data communication may include electronic packet switching service (EPSS) data and caption call service (CCS) data. EPSS data may include log-in data, data for property synchronization, contact information, settings, logging information, etc. CCS data may include data used to facilitate transcription of a voice signal. For example, the CCS data may include voice signal data (e.g., of the far end) that the communication device **310** may transmit to the relay service **130**. The CCS data may also include the text caption data that the relay service **130** transmits back to the communication device **310** for display. In embodiments that include video data, such video data may be communicated with the relay service **130** through the wireless port **340**. In some embodiments, the video data may be communicated separately from voice data. For example, the relay service **130** may split video data and

voice data that is sent to the communication device **310**. In some embodiments, the communication device **310** may be configured to split video data and voice data that is received together. Video data may be useful for hearing-impaired users who are deaf to facilitate communication with the relay service **130** to provide sign language interpretive services for the conversation.

With respect to communication with the second communication device **120**, the communication device **310** may communicate (e.g., transmit and receive) digital voice data (e.g., VoIP data) wirelessly through the wireless port **340**. The digital voice data may include the voice signals passing to and from the second communication device **120** during a conversation. Even though this digital voice data is received by the communication device **310**, the communication device **310** still may not be able to process the digital voice data to convert to audible sound to produce the hearing-impaired user. Thus, the digital voice data may still need to be converted into an analog voice signal that the communication device **310** can process and support. The communication device **310** may be configured to route the digital voice data **302** (e.g., SIP data) to the ATA device **320**. The ATA device **320** may be configured to convert the incoming digital voice data **302** into analog voice data **304** (e.g., POTS data) that is then transmitted back to the communication device **310**. Similarly, the ATA device **320** may be configured to convert the outgoing analog voice data **304** into digital voice data **302** that is transmitted back to the communication device **310** to again act as a router for the digital voice data **302** for transmission to the second communication device **120** over the wireless port **340**. As a result, the communication device **210** that itself is not configured to communicate over a digital voice network can do so with the assistance of the ATA device **320** providing the conversion of the voice data between the analog and digital domains. However, the ATA device **320** is no longer required to be coupled with a network connector (e.g., Ethernet patch connector) to receive the digital voice data as the digital voice data is received by the communication device **310** acting as a router for such digital voice data. Because the connection of the ATA device **320** and a network connector is no longer required, the options for placement of the communication device **310** and the ATA device **320** may be more flexible. For example, the communication device **310** and the ATA device **320** no longer need to be located close to a network connector for the wired connection therebetween. As a result, the communication device **310** and the ATA device **320** may be located anywhere within the wireless (e.g., Wi-Fi) coverage zone so long as the communication device **310** and the ATA device **320** have access to the power source **350**. In addition, the installation of the communication device **310** may be more simple, and the wiring may be reduced. The communication device **310** may also be relocatable without needing to rewire the hearing-impaired user's house.

In some embodiments, one of the ATA device **320** or the communication device **310** may not be coupled directly to the power source **350**. For example, the power provided to the ATA device **320** may be provided by the communication device **310**. In such an embodiment, the communication device **310** may be configured to provide power to the ATA device **320** through a wired connection (e.g., power over Ethernet (POE), USB, etc.). In some embodiments, the wired connection that provides data may also be used to provide power to the ATA device **320**. Similarly, it is contemplated that the ATA device **320** may provide power to the communication device **310**. In some embodiments, power may be provided wirelessly (e.g., through mutual inductive coupling). Such embodiments may further improve the flexibility

of the placement of the communication device **310** and/or the ATA device **320** if direct access to the power source **350** is limited.

In some embodiments, the communication device **310** may be configured to use routing tables to pass the network packets of the digital voice data to/from the ATA device **320**. In some embodiments, the communication device **310** may connect to a dynamic host configuration protocol server (DHCP) server so that the communication device **310** can acquire an IP address dynamically for the ATA device **320**. For example, the communication device **310** may be configured to maintain its own address (e.g., MAC address) for the ATA device **320**. The communication device **310** may be configured to perform IP masquerading for routing communication between the second communication device **120** and the ATA device **320**. As a result, the ATA device **320** may not be aware that it is connected to the communication device **310**. In some embodiments, the ATA device **320** may be set with a fixed IP address, which may eliminate the need for a DHCP server. Other protocols (e.g., IPv6, IP-Next, etc.) are also contemplated.

In addition, communication from the communication device **310** to the ATA device **320** may include a multi-cast signal. The multi-cast signal may include a conference call, webinar, etc. The multi-cast signal (e.g., RTP) may be transmitted by the communication device **310** to multiple devices, and the ATA device **320** may be configured to receive and translate the multi-cast signal to the analog voice signal **304**.

In addition to converting between digital voice data **302** and analog voice data **304**, the ATA device **320** may be configured to perform additional functions, such as call waiting, call blocking, facilitating conference calls with multiple connections, provide additional telephone connections and SIP connections to other devices, etc. In addition, the communication device **310** may be configured to configure the ATA device **320**. For example, the communication device **310** may be configured to enable and disable features (e.g., call waiting, call blocking, etc.) of the ATA device **320**. In some embodiments, the communication device **310** may also be configured to set the ATA device **320** as a fixed address device and provide the IP address to the ATA device **320**. In addition, the communication device **310** may transmit routing information and the domain name server (DNS) to the ATA device **320**. In some embodiments, the communication device **310** may also be configured to provide DHCP services for the ATA device **320** and then masquerade the traffic to and from the ATA device **320** as described above.

It should be recognized that the block diagram of FIG. 3 may be in a simplified form and that other components may be present to improve the operation and/or add additional functionality. For example, some embodiments may have a pre-amplifier between the ATA device **320** and the communication device **310**, which may be configured to amplify the analog voice data **304**. In addition, there may be a voicemail box or other recording device as part of the system, among other contemplated additional features that may be desirable to offer.

For embodiments that include video data, the voice data and video data may be split prior to being received by the communication device **310** through the wireless data port **340**. The communication device **310** may route the digital voice data **302** to the ATA device **320** and communicate with the ATA device **320** as discussed above. The video data may lag relative to the voice data, and the communication device **310** may be configured to synchronize the video data and the audio data when presented to the hearing-impaired user. In some embodiments, the communication device **310** may

receive video data and digital voice data together through the wireless data port **340**, and the communication device **310** may be configured to split the digital voice data prior to transmitting to the ATA device **320**.

FIG. 4 is a simplified block diagram of the communication device **310** of FIG. 3. The communication device **310** may include a processor **415** operably coupled to a memory **420**, a wireless data port **430**, a digital data port **440**, an analog data port **445**, an electronic display **450**, and a camera **460**. Other I/O devices may be included (e.g., a speaker, microphone, touch screen, keypad, etc.) to facilitate other communications of the communication device **210**. The memory **420** may include a computer-readable medium, comprising any of a random access memory (RAM), a read-only memory (ROM), a Flash memory, other suitable memory devices, and combinations thereof. The memory **420** may include instructions that may be executed by the processor **415** to implement the operations described herein. For example, the routing tables and other instructions for routing the digital voice data to/from the ATA device **320** (FIG. 3) may be stored therein. The electronic display **450** may be configured to display the text captions as discussed above for embodiments that include a captioned communication device. The electronic display **450** may be configured to display video as discussed above for embodiments that include a video communication device. The camera **460** may be configured to capture video for embodiments that include video communication devices.

The communication device **310** may be configured to communicate with another communication device and/or relay service as discussed above. For example, the communication device **310** may be configured to communicate with the ATA device **320** (FIG. 3) through the digital data port **440** and the analog data port **445**. The communication device **310** may also be configured to communicate with the relay service **130** (FIG. 1) and the second communication device **120** (FIG. 1) through the wireless data port **430**. The digital voice data communication between the communication device **310** and the second communication device **120** may be routed to the ATA device **320** as described above.

FIG. 5 is a simplified flowchart illustrating a method of facilitating communication in a communication network including a communication device and a relay service according to an embodiment of the disclosure.

At operation **510**, the communication device may receive digital voice data from an IP network. The digital voice data may be received by a wireless data port of the communication device, which may also be coupled with the relay service configured to provide interpretive assistance (e.g., text captions) for assisting hearing-impaired users communicate. At operation **520**, the communication device may route the digital voice data to an ATA device. The ATA device may be configured to convert the digital voice data to analog voice data. At operation **530**, the communication device may receive the analog voice data from the ATA device. Similarly, the communication device may transmit analog voice data to the ATA and receive digital voice data in return. At operation **540**, the voice data and/or caption data may be communicated with the relay service through the wireless port of the communication device.

While certain illustrative embodiments have been described in connection with the figures, those of ordinary skill in the art will recognize and appreciate that embodiments encompassed by the disclosure are not limited to those embodiments explicitly shown and described herein. Rather, many additions, deletions, and modifications to the embodiments described herein may be made without departing from the scope of embodiments encompassed by the disclosure,

11

such as those hereinafter claimed, including legal equivalents. In addition, features from one disclosed embodiment may be combined with features of another disclosed embodiment while still being encompassed within the scope of embodiments encompassed by the disclosure as contemplated by the inventors.

What is claimed is:

1. A communication system comprising:
 - an analog telephone adaptor (ATA) device configured to convert digital voice data to analog voice data, and analog voice data to digital voice data; and
 - a communication device specifically configured for use by a hearing-impaired user, the communication device comprising:
 - an electronic display;
 - a wireless data port;
 - a digital data port operably coupled with the ATA device;
 - an analog data port operably coupled with the ATA device; and
 - a processor operably coupled with the electronic display, the digital data port, the analog data port, and the wireless data port, wherein the processor is configured to:
 - coordinate communication with a second communication device through the wireless data port during a communication session with the second communication device;
 - coordinate communication of caption call service (CCS) data with a remote captioning service through the wireless data port during the communication session; and
 - coordinate communication with the ATA device through both the digital data port and the analog data port during the communication session such that:
 - far-end digital voice data received by the wireless data port from the second communication device is routed by the processor to the ATA device through the digital data port of the communication device;
 - the far-end digital voice data received by the wireless data port from the second communication device is also routed by the processor to the remote captioning service through the wireless data port of the communication device;
 - far-end analog voice data received from the ATA device is received through the analog data port of the communication device;
 - near-end analog voice data transmitted the ATA device is transmitted through the analog data port of the communication device; and
 - near-end digital voice data received from the ATA device is routed by the processor to the second communication device through the wireless data port of the communication device.
2. The communication system of claim 1, wherein the CCS data includes the far-end digital voice data transmitted to the remote captioning service, and text caption data received from the remote captioning service that is a text transcription of the far-end digital voice data.
3. The communication system of claim 1, wherein the processor of the communication device is further configured to coordinate electronic packet switching service (EPSS) data with the remote captioning service through the wireless data port.

12

4. The communication system of claim 3, wherein the EPSS data includes at least one of log-in data, synchronization data, contact information, settings, logging information, or a combination thereof.

5. The communication system of claim 1, wherein the communication device is coupled directly to a power source such that power is provided from the communication device to the ATA device through a wired connection therebetween.

6. The communication system of claim 1, wherein the ATA device is coupled directly to a power source such that power is provided from the ATA device to the communication device through a wired connection therebetween.

7. The communication system of claim 1, wherein the processor of the communication device is configured to use routing tables to pass network packets of the digital voice data to and from the ATA device.

8. The communication system of claim 1, wherein the processor of the communication device is configured to acquire an IP address for the ATA device from a dynamic host configuration protocol server.

9. The communication system of claim 1, wherein the processor of the communication device is configured to maintain its own address for the ATA device.

10. The communication system of claim 1, wherein the processor of the communication device is configured to set the ATA device as a fixed address device and provide an IP address to the ATA device.

11. The communication system of claim 1, wherein the processor of the communication device is configured to transmit routing information and domain name server (DNS) information to the ATA device.

12. The communication system of claim 1, wherein the processor is configured to receive video data through the wireless data port and present the video data on the electronic display of the communication device.

13. The communication system of claim 12, wherein the processor is further configured to synchronize the video data with the far-end analog voice data received from the ATA device.

14. The communication system of claim 1, wherein the processor of the communication device is further configured to enable and disable features performed by the ATA device.

15. A method of facilitating communication in a communication network including a communication device and a remote captioning service, the method comprising:

- receiving a far-end digital voice signal wirelessly from a second communication device via a wireless data port of a first communication device during a communication session between the first communication device and the second communication device;

- routing the far-end digital voice signal from the first communication device to a remote captioning service via the wireless data port of the first communication device;

- routing the far-end digital voice signal from the first communication device to an analog telephone adaptor (ATA) device via a digital data port of the first communication device;

- converting the far-end digital voice signal to far-end analog voice signal by the ATA device;

- receiving the far-end analog voice signal from the ATA device via an analog data port of the first communication device;

- transmitting a near-end analog voice signal from the first communication device to the ATA device via the analog data port of the first communication device;

- converting the near-end analog voice signal to near-end digital voice signal by the ATA device;

13

receiving the near-end digital voice signal from the ATA device via digital data port of the first communication device;

routing the near-end digital voice signal from the first communication device to the second communication device via the wireless data port of the first communication device;

receiving text caption data wirelessly from the remote captioning service via the wireless data port of the first communication device; and

reproducing the far-end analog voice signal and the text caption data by the first communication device for a hearing-impaired user during a communication session between the first communication device and the second communication device that is assisted by the remote captioning service.

16. The method of claim 15, wherein routing the far-end digital voice signal from the first communication device to the ATA device includes the first communication device using at least one of the following methods: routing tables, IP masquerading, dynamic IP addresses, fixed IP addresses, and multi-cast transmission.

17. The method of claim 15, further comprising performing at least one of the following functions through by the ATA device: call waiting, call blocking, facilitating conference calls with multiple connections, providing additional telephone connections or SIP connections to other devices, or combinations thereof.

18. The method of claim 17, further comprising enabling or disabling the functions of the ATA device using the first communication device.

19. The method of claim 15, further comprising: receiving video data wirelessly from the second communication device via the wireless data port of a first communication device; and displaying the video data on an electronic display of the first communication device that is synchronized with the far-end analog voice signal when reproduced by the first communication device.

20. A communication system comprising: a first communication device specifically configured for use by a hearing-impaired user for providing text captions during a communication session with a second communication device, the first communication device

14

having a processor operably coupled with a wireless data port, an analog data port, a digital data port, and an electronic display;

a remote captioning service configured to generate the text captions during the communication session; and

an analog telephone adaptor (ATA) device operably coupled with the analog data port and the digital data port of the first communication device, wherein during the communication session:

the first communication device is configured to:

- receive a far-end digital voice signal from the second communication device through the wireless data port;
- route the far-end digital voice signal to the ATA device through the digital data port;
- route the far-end digital voice signal to the remote captioning service through the wireless data port;
- receive a far-end analog voice signal from the ATA device through the analog data port;
- transmit a near-end analog voice signal to the ATA device through the analog data port;
- receive a near-end digital voice signal from the ATA device through the digital data port;
- route the near-end digital voice signal to the second communication device through the wireless data port;
- receive text captions of the far-end digital voice signal from the remote captioning service through the wireless data port;
- display the text captions on the electronic display; and
- reproduce audio from the far-end analog voice signal; and

the ATA device is configured to:

- receive the far-end digital voice signal from the first communication device;
- convert the far-end digital voice signal to the far-end analog voice signal;
- transmit the far-end analog voice signals to the first communication device;
- convert the near-end analog voice signal to near-end digital voice signal; and
- transmit the near-end digital voice signal to the first communication device.

* * * * *

UNITED STATES PATENT AND TRADEMARK OFFICE
CERTIFICATE OF CORRECTION

PATENT NO. : 9,357,064 B1
APPLICATION NO. : 15/005828
DATED : May 31, 2016
INVENTOR(S) : Sean Walton

Page 1 of 1

It is certified that error appears in the above-identified patent and that said Letters Patent is hereby corrected as shown below:

In the claims:

CLAIM 1, COLUMN 11, LINE 51, change "transmitted the ATA" to --transmitted from
the ATA--

Signed and Sealed this
Sixth Day of September, 2016

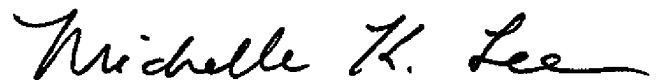

Michelle K. Lee
Director of the United States Patent and Trademark Office